



SUPERLIFT®

S U S P E N S I O N

Superlift Track Bar Bracket for 2005 - 2007 FORD F-250 / F-350 SUPER DUTY 4WD INSTALLATION INSTRUCTIONS

INTRODUCTION

Installation requires a professional mechanic. Prior to beginning, inspect the vehicles steering, driveline, and brake systems, paying close attention to the suspension link arms and bushings, anti-sway bars and bushings, tie rod ends, pitman arm, ball joints and wheel bearings. Also check the steering sector-to-frame and all suspension-to-frame attaching points for stress cracks. The overall vehicle must be in excellent working condition; repair or replace all worn parts.

Read instructions several times before starting. Be sure you have all needed parts and know where they install. Read each step completely as you go.

NOTES:

- Front end realignment is necessary.
- A foot-pound torque reading is given in parenthesis () after each appropriate fastener.
- Do not fabricate any components to gain additional suspension height.
- After drilling, file smooth any burrs and sharp edges.
- Prior to attaching components, be sure all mating surfaces are free of grit, grease, undercoating, etc.
- A factory service manual should be on hand for reference.
- Use the check-off box "☐" found at each step to help you keep your place. Two "☐☐" denotes that one check-off box is for the driver side and one is for the passenger side. Unless otherwise noted, always start with the driver side.

PARTS LIST ... The part number is stamped into each part or printed on an adhesive label. Identify each part and place the appropriate mounting hardware with it.

PART NO	DESCRIPTION <small>(Qty.- if more than one)</small>	NEW ATTACHING HARDWARE <small>(Qty.- if more than one)</small>
55-01-9000	front track bar bracket	
55-01-9022	compression stop bracket, front, driver side	(1) 3/8" x 1-1/4" bolt (1) 3/8" x 1" bolt (1) 3/8" USS washer (2) 3/8" nyloc nut
55-02-9022	compression stop bracket, front, passenger side	(1) 3/8" x 1-1/4" bolt (1) 3/8" x 1" bolt (1) 3/8" USS washer (2) 3/8" nyloc nut
55-03-9022.....	(2) track bar key	

0034.....Superlift badge alcohol wipe pad
 00461decal, "Warning To Driver"

INSTALLATION PROCEDURE

1) PREPARE VEHICLE...

- Disconnect the track bar from its attachment point on the frame and let the bar hang. Save all hardware for re-use.
- Unbolt the factory track bar bracket from the frame. Save all hardware for re-use.

2) TRACK BAR BRACKET...

NOTE: Inspect the area of the frame crossmember where the track bar bracket attaches. Often there is an excessive amount of undercoating build-up on the crossmember, especially on the back (rearward facing) portion of the crossmember where the undercoating has pooled up. Scrape off any excessive undercoating to prevent the track bar bracket from loosening over time.

- [DIAGRAM – INSTALLING TRACK BAR BRACKET] Position the Superlift track bar bracket (#55-01-9000) on the frame in the same place as the original and secure using the factory hardware. There are a total of five bolts; three on a retaining tab plus two separate bolts. Once all the bolts are started, tighten (129).

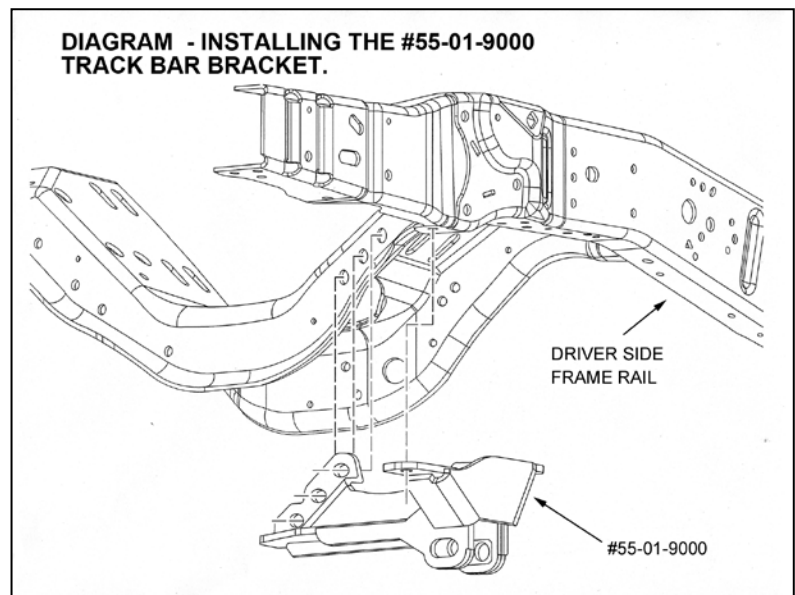

3) COMPRESSION TRAVEL STOP EXTENSIONS...

- Pry the front compression travel stops out of their mounting cups, then unbolt the cups from the frame.
- On each side, position a compression travel stop extension (#55-01-9022 driver side and #55-02-9022 passenger side) on the frame in the location that the stop cup was just removed and secure it to the frame using the supplied 3/8" x 1-1/4" bolts, washer, and nyloc nut. Tighten (23).
- Attach the factory compression stop cup to the "01" and "02" brackets using the supplied 3/8" x 1" bolt, washer, and nyloc nut. Tighten (23).
- Press the factory compression stops back into their mounting cups.

4) TRACK BAR...

- Observe the two supplied track bar keys and note that there is a notch in one end of each key. Position these notches toward the driver side of the vehicle and insert them into the slotted holes of the track bar bracket. Line up the track bar with the slotted hole of the new track bar bracket. Insert the factory track bar bolt through the keys, bracket, and track bar and secure using the factory hardware. Tighten **(406)**.

IMPORTANT: Yes, the proper torque specification for the track bar eye bolt is **406 lb-ft**; this is not a typographical error. If the appropriate torque wrench is not available, tighten the bolt as much as possible, then take the vehicle to the Ford Dealer or a heavy equipment repair shop to perform the final torque operation. Proper torque on this bolt is critical.

5) FINAL CLEARANCE and TORQUE CHECK...

- With vehicle on floor, cycle steering lock-to-lock and inspect the tires / wheels, and the steering, suspension, and brake systems for proper operation, tightness, and adequate clearance.

6) SUPERLIFT WARNING DECAL...

- Install the WARNING TO DRIVER decal on the inside of the windshield, or on the dash, within driver's view. Refer to the "NOTICE TO DEALER AND VEHICLE OWNER" section below.

7) ALIGNMENT...

Realign vehicle to factory specifications. Alignment must be performed by a qualified professional.

Limited Lifetime Warranty / Warnings

Your Superlift® product is covered by the Limited Warranty explained below that gives you specific legal rights. This limited warranty is the only warranty Superlift® makes in connection with your product purchase. Superlift® neither assumes nor authorizes any retailer or other person or entity to assume for it any other obligation or liability in connection with this product or limited warranty.

What is covered? Subject to the terms below, Superlift® will repair or replace its products found defective in materials or workmanship for so long as the original purchaser owns the vehicle on which the product was originally installed. Your warrantor is LKI Enterprises, Inc. d/b/a Superlift® Suspension Systems ("Superlift®").

What is not covered. Your Superlift® Limited Warranty does not cover products, parts or vehicles Superlift® determines to have been damaged by or subjected to:

- Alteration, modification or failure to maintain.
- Normal wear and tear (bushings, tie-rod ends, etc.). Scratches or defects in product finishes (powdercoating, plating, etc.),
- Damage to or resulting from vehicle's electronic stability system, related components or other vehicle systems.
- Racing or other vehicle competitions or contests. Accidents, impact by rocks, trees, obstacles or other aspects of the environment.
- Theft, vandalism or other intentional damage.

Remedy Limited to Repair / Replacement. The exclusive remedy provided hereunder shall, upon Superlift's inspection and at Superlift's option, be either repair or replacement of product or parts covered under this Limited Warranty. Customers requesting warranty consideration should contact Superlift® by phone (1-800-551-4955) to obtain a Returned Goods Authorization number. All removal, shipping and installation costs are customer's responsibility.

If a replacement part is needed before the Superlift® part in question can be returned, you must first purchase the replacement part. Then, if the part in question is deemed warrantable, you will be credited / refunded.

Other Limitations - Exclusion of Damages - Your Rights Under State Law

- Neither Superlift® nor your independent Superlift® dealer are responsible for any time loss, rental costs, or for any incidental, consequential or other damages you may have.
- This Limited Warranty gives you specific rights. You may also have other rights that vary from state to state. For example, while all implied warranties are disclaimed herein, any implied warranty required by law is limited to the terms of our Limited Lifetime Warranty as described above. Some states do not allow limitations of how long an implied warranty lasts and / or do not allow the exclusion or limitation of incidental or consequential damages, so the limitations and exclusions herein may not apply to you.

Important Product Use and Safety Information / Warnings

As a general rule, the taller a vehicle is, the easier it will roll over. Offset, as much as possible, what is lost in rollover resistance by increasing tire track width. In other words, go "wide" as you go "tall". Many sportsmen remove their mud tires after hunting season and install ones more appropriate for street driving; always use as wide a tire and wheel combination as feasible to enhance vehicle stability. We strongly recommend, because of rollover possibility, that the vehicle be equipped with a functional roll bar and cage system. Seat belts and shoulder harnesses should be worn at all times. Avoid situations where a side rollover may occur.

Generally, braking performance and capabilities are decreased when significantly larger / heavier tires and wheels are used. Take this into consideration while driving. Also, changing axle gear ratios or using tires that are taller or shorter than factory height will cause an erroneous speedometer reading. On vehicles equipped with an electronic speedometer, the speed signal impacts other important functions as well. Speedometer recalibration for both mechanical and electronic types is highly recommended.

Do not add, alter, or fabricate any factory or aftermarket parts to increase vehicle height over the intended height of the Superlift product purchased. Mixing component brands is not recommended.

All Superlift® material is copyrighted. All images found in this catalog and in any Superlift® marketing forums are the sole property of or licensed to Superlift®. Any reproduction of said materials, in part or in whole, without the express written permission of Superlift® is strictly forbidden. Superlift®, Rockrunner™, Swamprunner™, Superide™, Superide SS™ and SSR™, Black Diamond®, XCL™, X2™ Super Trac™, Torque Max™, Torque Max SS™, eXtreme Ring™, Rail Wrap™, Bullet Proof Brake Hose™, TruSpeed™, Frame Integrated Technology™, F.I.T. Series™ and Rock Fink™ are registered trademarks of Superlift® Suspension Systems. Superlift® Suspension Systems is a Division of Bret Lovett's Lift Kits Incorporated.

SUPERLIFT SUSPENSION SYSTEMS

300 Huey Lenard Loop Rd.
West Monroe, Louisiana 71292
Phone: (318) 397-3000
Sales / Tech: 1-800-551-4955
FAX: (318) 397-3040
www.superlift.com